

1 THE TWO CITIES

Dr. Jack Moorman, who spent many years in researching the question of Bible versions, has stated that the transmission of the Greek text of the New Testament is essentially a "tale of two cities", viz., Antioch and Alexandria. Dr. Moorman writes: "Just as surely as the King James text was woven into the spiritual life of Antioch in Syria, so was the modern versions text in Alexandria. Today a person must decide whether he is more comfortable with a Bible whose roots go back to one or the other of these two cities...certainly Antioch has by far the most glorious heritage."

ANTIOCH: Here was the springboard for the Gentile church. It became the center for Gentile Christians just as Jerusalem was for the Jews. "The disciples were called Christians first at Antioch" (Acts 11:26). Antioch was the center for the outreach of the apostle Paul and his missionary journeys. Many of the disciples also visited Antioch. Antioch was the 'heartbeat' of Christianity.

ALEXANDRIA: The place where most of the modern texts and translations originated, had no such glory. It is true, however, that Alexandria became a center of intellectualism. Such men as Clement and Origen were

TRADITIONAL TEXT LINE

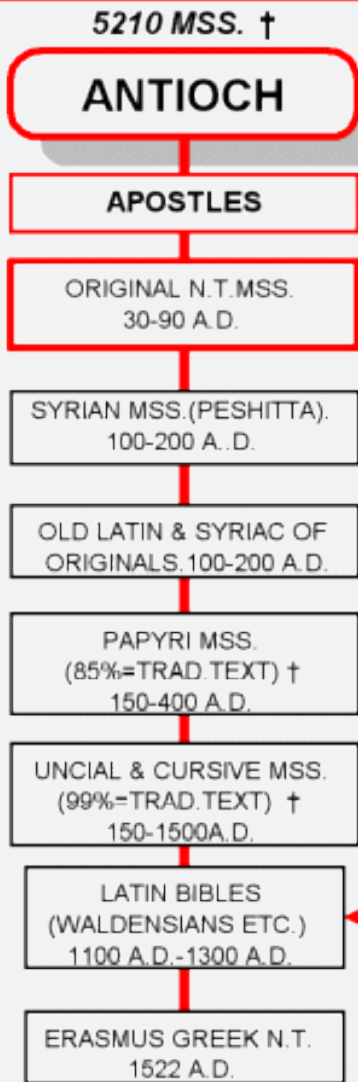

PROVIDENTIAL PRESERVATION OF THE TEXT OF THE NEW TESTAMENT

CORRUPTION OF THE SCRIPTURES (Gnosticism, Arianism, pagan philosophy)



ALEXANDRIAN TEXT LINE

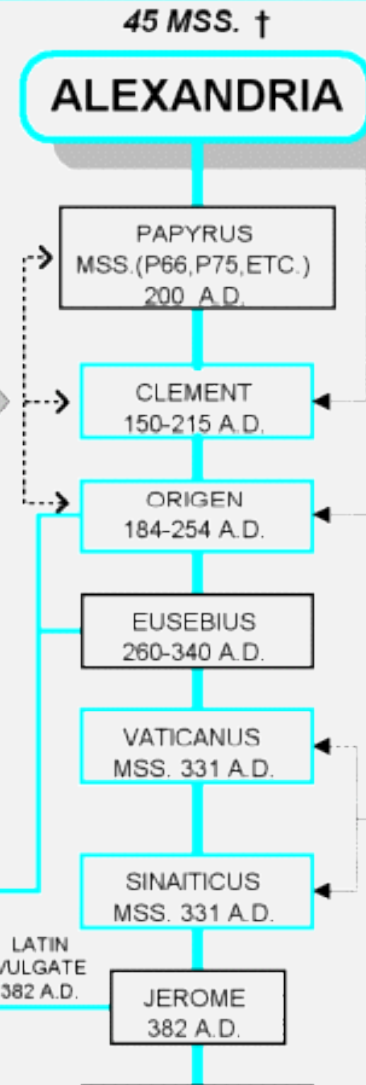

REFORMATION

3 THE TWO HERETICS*

CLEMENT: He accepted Greek philosophy and the Apocrypha as divinely authoritative. He was head of the catechetical school at Alexandria and believed that salvation could be obtained through various means including baptism, faith and works, faith alone etc.

ORIGEN: He also became head of the catechetical school. A man of superior intellect he however denied the Bible's historicity, eternal punishment, the Holy Spirit's eternity, salvation by grace etc. He was given to the allegorizing of scripture.

* Data from: "Final Authority" by William P. Grady.

4 THE TWO FALSE WITNESSES **

Discarded and hidden for 1500 years, these two corrupted manuscripts form the basis of all MODERN VERSIONS. They disagree with each other in over 3000 places in the Gospels alone. It is the **VATICAN MSS** (which include the Apocrypha) that the translators mostly relied upon. Both had their roots in Alexandria and show the influence of Origen.

** Data from H.C. Hoskier's "Codex B and its Allies".

A total of 43 other manuscripts indicate some support for this text compared to 5210 which support the Traditional Text. †

John W. Burgon. states: "These are two of the least

Alexandria became a center of intellectualism. Such men as Clement and Origen were active in this area. It was also noted as a place where every deviant sect was represented. Religious corruption and false doctrines were prevalent including Gnosticism, Arianism, pagan philosophy, etc. Alexandria was the place where the intellectuals of Christianity were attracted.

2 THE TWO ESSENTIALS

Since God has inspired his Word has He also preserved His Word? Has He preserved it for every generation?

The Westminster Confession(1646) states: "The Scriptures were immediately inspired of God and under His singular care and providence kept pure in all ages."

The Bible has the final say in the matter: "The words of the Lord are pure words...Thou shalt keep them, O Lord, Thou shalt preserve them from this generation for ever. (Psalm 12: 6,7).

If we accept the Inspiration of Scripture we must also accept that every word has been and will be Preserved through the ages in the church. Both together are essential doctrines.

Hark Ministries ©1998.DRG.No.5(d).
Prepared by H.N.Arkeil. Computer Graphics by S.H.Arkeil.
Permission granted for use. No changes permitted.
Web site: WWW.sentex.net/~hark
E-Mail: hark@sentex.net

